

4/2, 4/3 Directional Control Valve, NG 25 ISO 4401, Pilot NG 4, ISO 4401, horizontal Technical Data Sheet



- Pilot controlled piston valve
- High switching power
- Short switching time
- Energy saving due to minimized flow resistivity
- With internal or external pilot oil supply
- Easy service: solenoid can be changed without leakage while the valve is under system pressure
- Solenoids can be rotated 3 x 90°, allowing alternative connector positions

Technical Data

General

Type of valve	piston valve
Operation	electric
Mounting	6 x M12 x 60 DIN912
Connection of ports	mounting plate
Mounting positions	any position
Ambient temperature	-5 to +50 °C
Mass valve	10.5 kg

Hydraulic

Operating pressure P,A,B	max. 280 bar
Operating pressure T	max. 150 / 280*** bar
Pilot pressure range	15 bis 120 bar
Pilot volume oil	4/3 valves: 2x 8,3 cm ³ 4/3 valves: 9,6 cm ³
Hydraulic oil temperature	-10 to +70 °C
Viscosity range	10 to 300 mm ² /s
Max. flow	450 l /min

Electric

Voltage (±10%)	24 V DC	230V, 50Hz AC
Switching time off*	50 ms	50 ms
Switching time off**	60 ms	40 ms
Power consumption P20	28 W	
Start up peak P20		35 VA
Duty factor	100%	100%
Protective system	IP65 at connected valve plug DIN 40050	

* at 24V DC ± 5%

** at terminal voltage = -50V at free circuit

*** at external pilot oil drain

Options

- Alternative voltages
- Alternative symbols - data sheet: 14607-DSH
- Alternative plugs
- Adjustable switching delay
- Electric monitoring of the spool position
- Stroke limitation (replace one-way restrictor)

Symbol

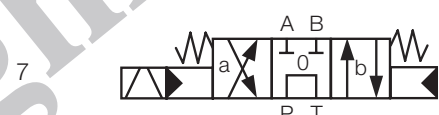
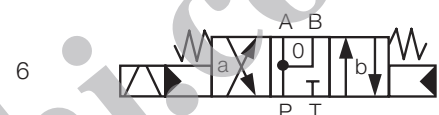
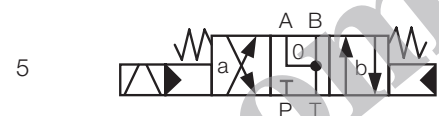
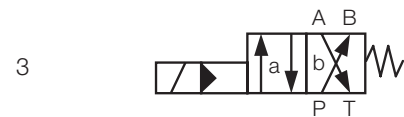
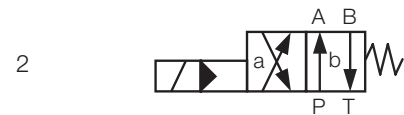

Electrical Connection

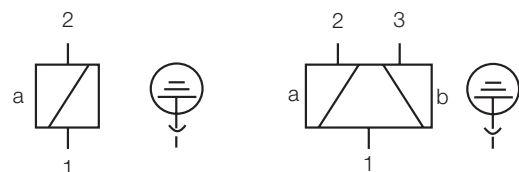

Characteristic Curve

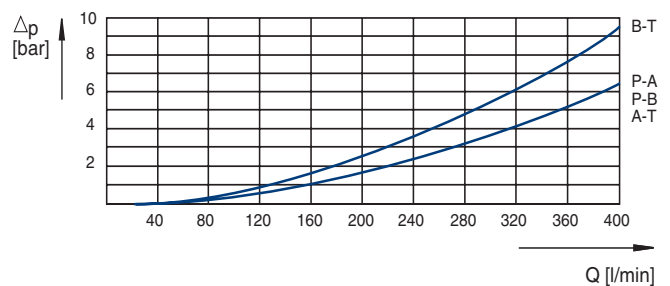

hydraulic oil 35 mm²/s, 50°C

Dimensional Drawing

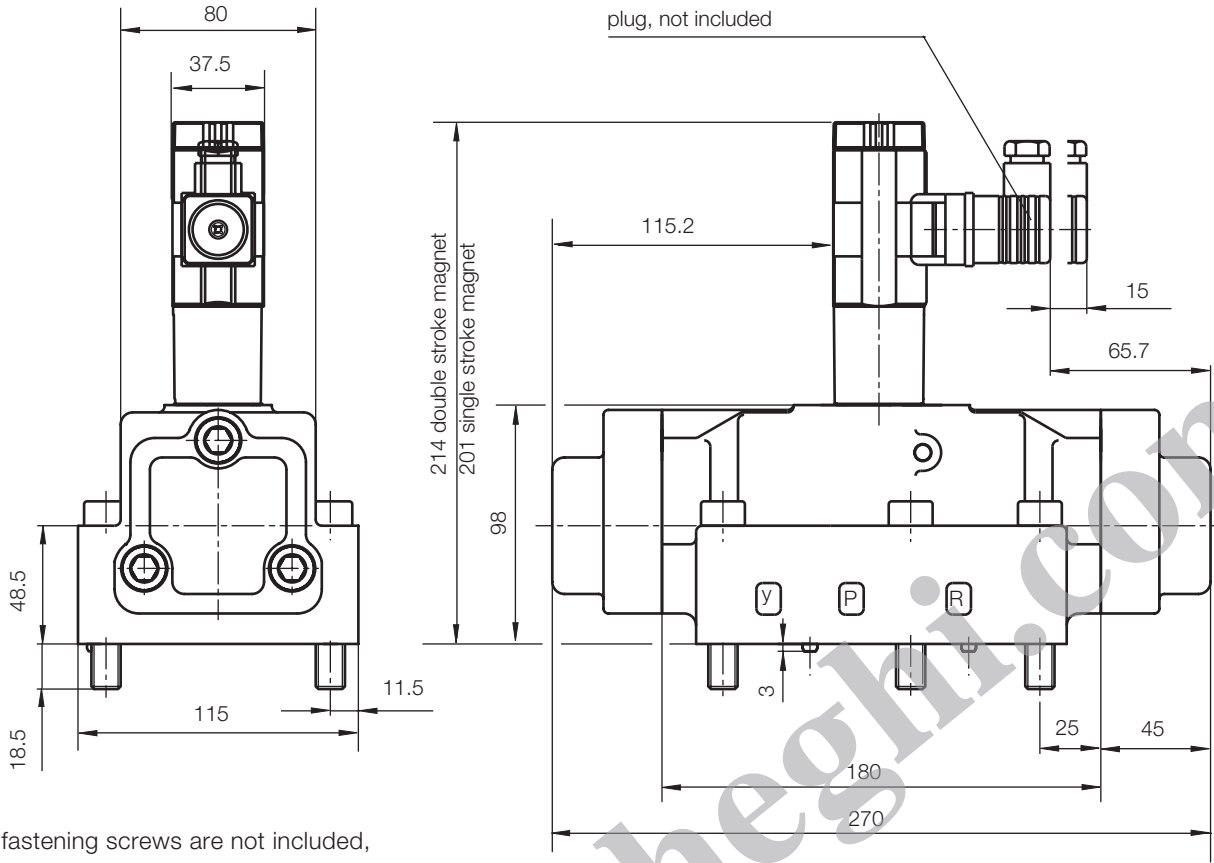

fastening screws are not included,
6x M12x65 DIN 912 - 10.9, MA = 80 Nm

all dimensions in mm

Port Connection Pattern

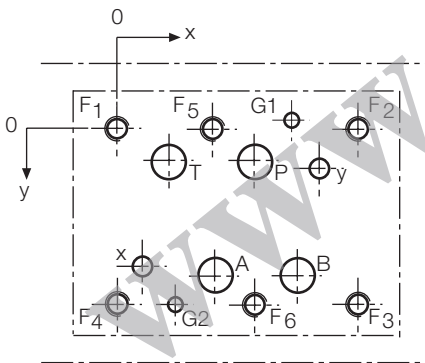

view: fastening side of mounting plate

	P	A	T	B	x	y	F1	F2	F3	F4	F5	F6	G1	G2
Ø max [mm]	25	25	25	25	11.2	11.2	-	-	-	-	-	-	7.5	7.5
x [mm]	77	53.2	29.4	100.8	17.5	112.7	0	130.2	130.2	0	53.2	77	94.5	29.4
y [mm]	27.5	74.6	17.5	74.6	73	19	0	0	92.1	92.1	0	92.1	-4.8	92.1

F: M12, thread depth min. 1.5 x Ø;

G: bore hole depth min. 1,5 x Ø;

x and y: only at external control.

Various single and multiple mounting plates are available.

Type Code

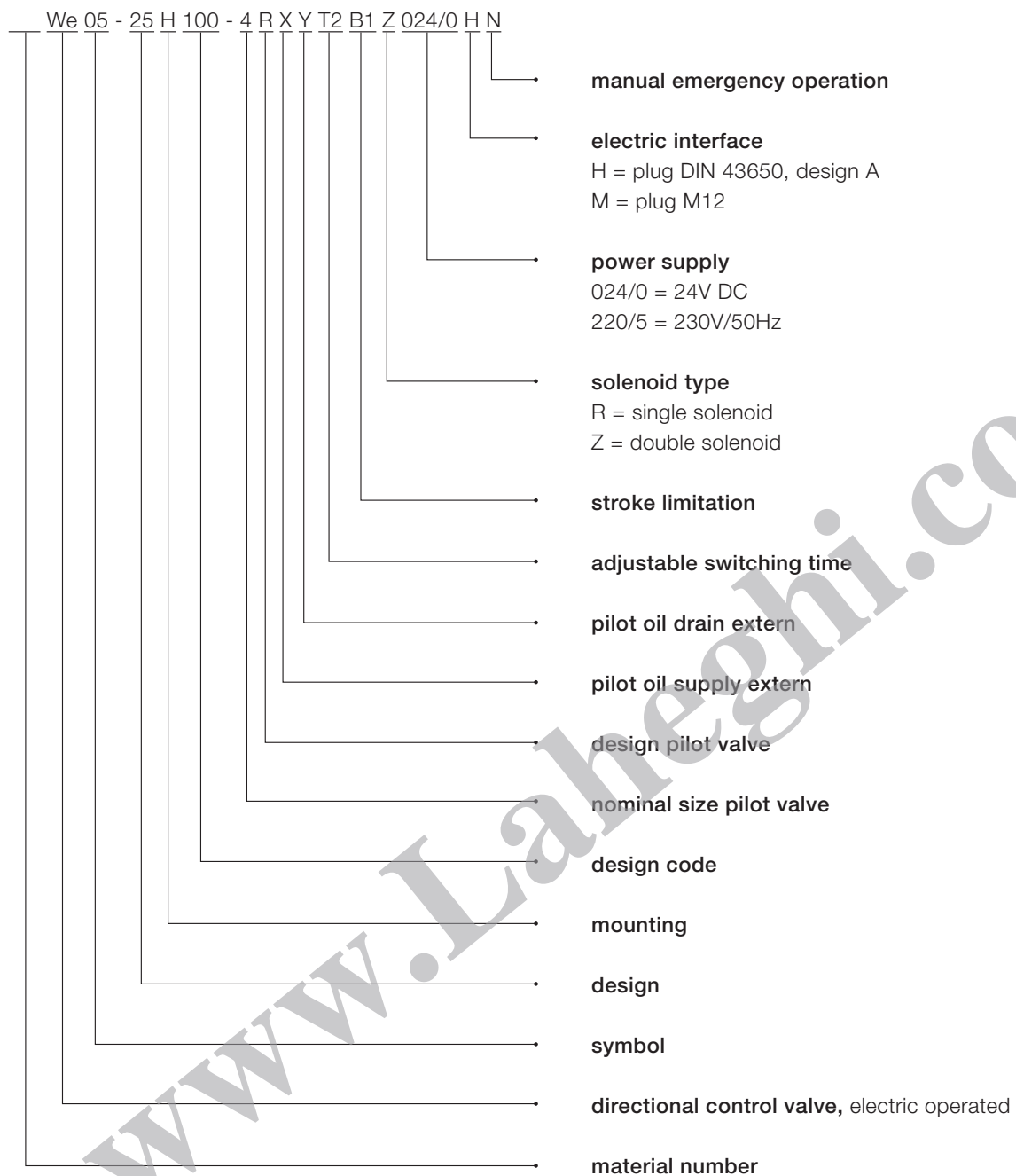

www.Laheghi.com

This is a translated document. Original language: german.
Legally binding language version of document: german.

Voith Turbo H + L Hydraulic GmbH & Co. KG
Schuckertstraße 15
71277 Rutesheim, Germany
Tel. +49 7152 992 3
Fax +49 7152 992 400
sales-rut@voith.com
www.voith.com/hydraulic-systems



VOITH
Engineered Reliability